

Grade : VI

Subject : Science

## ELECTRICITY

### Electricity Current

#### Electric Circuit

- A complete pathway for the flow or electric current.
- Electric current flows when the electric circuit is complete and closed.
- Electric current does not flow when the electric circuit is not complete or is open.

#### conductors

- Materials that allow electric current to pass through them.
- All metals are good conductors of electricity.
- Carbon is the only non- metal which is a good conductor

#### Insulators

- Materials which do not allow electric current to pass through them.
- Examples: Plastics ,rubber, wood, glass, polythene, PVC, etc.

#### Circuit Diagram

It is a symbolic representation of the electric circuit.

#### Components

#### Connecting Wires

- Help to conduct the electric current and complete the circuit.
- These are called leads or electrical cables.
- Wires are made up of metal and usually covered with plastic.
- The metal wire must touch the battery and the bulb connector to complete the circuit

#### Bulb

- Light up when an electric current flows through it.
- In a circuit, one lead must touch the bottom of the bulb and the other lead must touch the metal casing.

#### Switch

- Keeps the circuit off or on when a switch is on, a gap in the circuit is bridged by a conducting material through which the current flows.
- When the switch is off the conducting material is moved so that a gap is formed and the current stops flowing

#### Electric cell

- A cell has two terminals –a positive terminal and a negative terminal.
- Produces electricity by chemical reactions taking place between the chemicals placed inside the body of the cell.

#### Torch

- Parts of a torch
- A metallic or plastic case
  - Torch bulb
  - Glass reflector
  - Slide switch
  - Two or three cells
  - Metal spring attached to the slide switch

Working :

When the slide switch is slide forward ,cell contact is complete with the bulb lights up.

#### Battery

- Battery is made up of two or more cells joined together.
- Always connect the positive (+) terminal of one cell to the negative(-) terminal of another cell.

#### LED

- Light Emitting Diode, i.e., a device made from semiconducting material which has been given two impurities, phosphorus and boron.
- Allows current to flow in only one direction through it, and produce light.
- Made from semiconductors such as gallium arsenide and gallium phosphide.

## I. Know the Terms

- **Electricity** : The form of energy.
- **Solar cell** : A device that converts solar energy to electrical energy.
- **Electric Cell** : An electric cell is a device which converts chemical energy stored in it into electric energy.

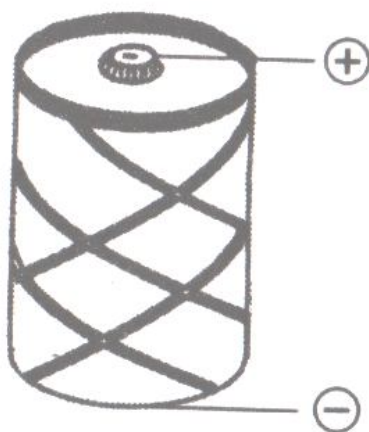

- **Filament** : The thin wire in the bulb which emits light is called filament of the bulb. It is made up of tungsten metal.
- **Open circuit** : When there is any gap in the circuit and bulb does not glow then it is called open circuit. The path for the flow of electricity to pass through the bulb is not complete.
- **Closed circuit**: When there is no gap in the path of electricity and bulb starts to glow then it is called closed circuit.

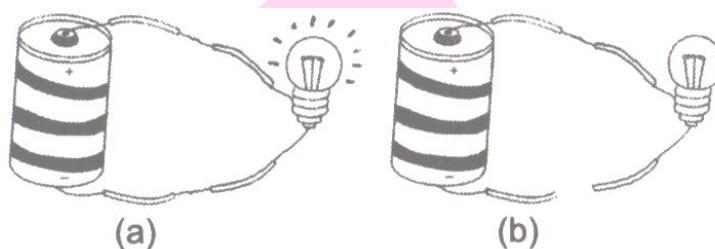

- **Conductors** : The materials which allow the electric current to pass through them are called conductors. Mostly metals are good conductors. Our body is also a good conductor of electricity.
- **Insulators** : The materials which do not allow the electric current to pass through them are called insulators, for example: rubber and wood are insulators.
- **Switch** : A device which is used to switch ON or OFF the circuit.
- **Current** : Continuous flow of charge is known as current.

## Objective Type Questions

(1 Mark each)

### I. Multiple choice questions

- Which of these appliances in your home is not run by electricity?  
(a) Geyser (b) Gas burner (c) Air conditioners (d) Music system
- Which of these does not conduct electricity?  
(a) Brass spoon (b) Silver jewellery (c) Steel tumbler (d) Plastic jug
- An electric cell can generate electric current in a/an :  
(a) Open circuit (b) Closed circuit (c) Both of these (d) None of these
- SI unit of current is :  
(a) ampere (b) volt (c) watt (d) hertz
- Which of these uses a chemical reaction to produce an electric current ?  
(a) An electric generator (b) A dry cell  
(c) Wind mill (d) All of these
- In an electric device which can easily close or open an electric circuit.  
(a) Filament (b) Electric bulb (c) Electric switch (d) Electric cell
- A material which does not allow the electricity to pass through it is known as  
(a) Conductor (b) Electric cell (c) Insulator (d) None of these
- Non-metals like and are good conductors of electricity :  
(a) Wood and paper (b) Graphite and gas carbon  
(c) Glass and rubber (d) None of these
- A material that allows the electricity to pass through it is :  
(a) Conductor (b) Insulator (c) Transistor (d) None of these
- Electric energy is produced from the within the cell.  
(a) Chemicals (b) Metals (c) Terminals (d) None of these
- Choose from the options a, b, c and d given in Fig. which shows the correct direction of current.

[NCERT Exemplar]

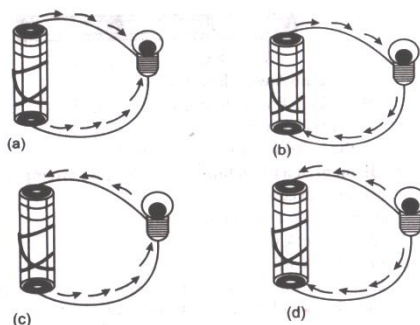

12. Choose the incorrect statement.

[NCERT Exemplar]

- (a) A switch is the source of electric current in a circuit.
- (b) A switch helps to complete or break the circuit.
- (c) A switch helps us to use electricity as per our requirement.
- (d) When the switch is open there is an air gap between its terminals.

13. In an electric bulb, light is produced due to the glowing of :

[NCERT Exemplar]

- (a) the glass case of the bulb
- (b) the thin filament
- (c) the thick wires supporting the filament
- (d) gases inside glass case of the bulb

14. In the following arrangement shown in Fig. the bulb will not glow if the ends A and B are connected with

[NCERT Exemplar]

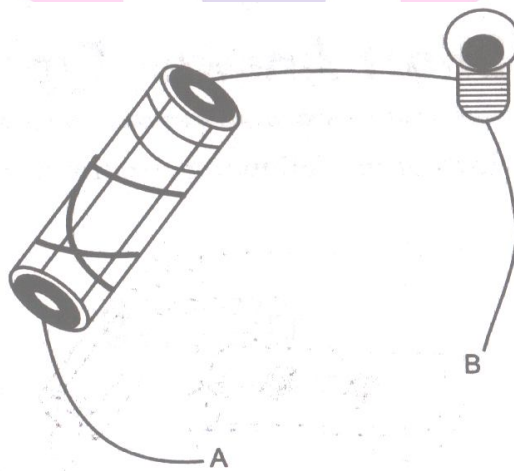

- (a) A steel spoon
- (b) A metal clip
- (c) A plastic clip
- (d) A copper wire

15. In the circuit shown in Fig., when the switch is moved to 'ON' position :

[NCERT Exemplar]

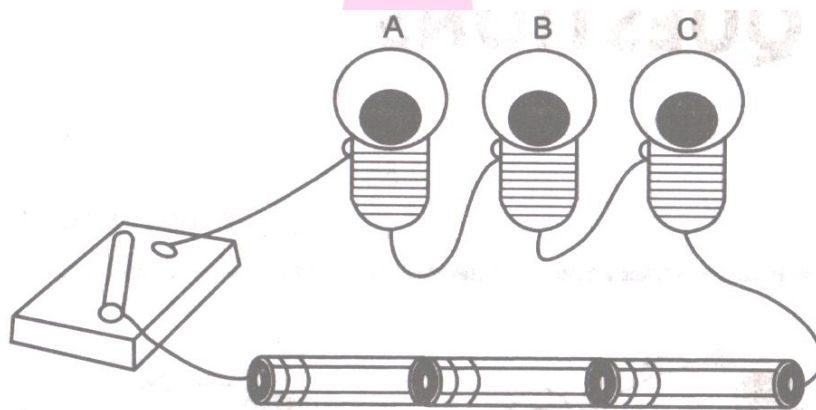

- (a) the bulb A will glow first
- (b) the bulb B will glow first
- (c) the bulb C will glow first
- (d) the bulbs will glow together.

16. Filament of a torch bulb is :

[NCERT Exemplar]

- (a) a metal case
- (b) metal tip at the centre of the base
- (c) two thick wires
- (d) a thin wire

17. Paheli is running short of connecting wires. To complete an electric circuit, she may use a :

[NCERT Exemplar]

- (a) glass bangle      (b) thick thread      (c) rubber pipe      (d) steel spoon

18. Which of the following is not a component of a circuit ?

- (a) Battery      (b) Wires      (c) Key      (d) Filament

19. What is used in a torch ?

- (a) Dry cell      (b) Secondary cell      (c) Generator      (d) Fuse

20. What is used in making or breaking a circuit ?

- (a) Plug      (b) Battery      (c) Wire      (d) Switch

1. (b)	2. (d)	3. (b)	4. (a)	5. (b)	6. (c)	7. (c)	8. (b)	9. (a)	10. (a)
11. (b)	12. (a)	13. (b)	14. (c)	15. (d)	16. (d)	17. (d)	18. (d)	19. (a)	20. (d)

**I. Match the following.**

Column A	Column B
a. Thin wire in the bulb that gives off light.	i. Conductors
b. Provides a complete path for electricity to pass.	ii. Insulator
c. Materials that allow electric	iii. Metal disc
d. Materials which do not allow electric current to pass	iv. Fused bulb
e. Negative terminal in the electric cell	v. Filament
f. A bulb that has broken filament	vi. Electric circuit

a. v	b. vi	c. i	d. ii	e. iii	f. iv
------	-------	------	-------	--------	-------

**I. True or False**

- The electric cell produces electric current.
- The black rod in a dry cell is lead rod.
- Electricity can pass through thermocol.
- When the filament of a bulb gets broken, it is termed as fused.
- A jute string can be used as connecting wire in an electrical circuit.
- Electric current can pass through the copper wire.
- We use electricity to operate pumps that lift water from wells.

8. Combination of two or more cells is called circuit.
9. Plastic is a conductor material.
10. Dry cell converts electrical energy into chemical energy.
11. Both electric cells and the bulbs have one terminal each.
12. The thin wire that gives off light is called the filament.
13. The bulb glows only when current flows through the circuit.
14. A fused bulb does not light up.
15. A key is made up of metal.
16. Conductors and Insulators are equally important for us.

1. True	2. False	3. False	4. True	5. False	6. True	7. True	8. False
9. False	10. False	11. False	12. True	13. True	14. True	15. True	16. True

### I. Fill in the blanks

1. An electric cell has \_\_\_\_\_ terminals.
2. A cell produces \_\_\_\_\_ terminals.
3. A device that makes or breaks a circuit is called \_\_\_\_\_.
4. Electrical switches, plugs, sockets, etc. are made of \_\_\_\_\_.
5. Handle of an electrician's screwdriver is made of \_\_\_\_\_.
6. A power station provides us \_\_\_\_\_.
7. An electric cell converts chemical energy to \_\_\_\_\_.
8. The electric cell and bulb have \_\_\_\_\_ terminals.
9. Materials that allow electric current to pass through them are called \_\_\_\_\_.
10. Materials that do not allow electric current to pass through them are called \_\_\_\_\_.
11. Our body is a \_\_\_\_\_ of electricity.
12. Be \_\_\_\_\_ when you handle an electric appliance.

1. two	2. electric current	switch	4. insulators
5. insulator	6. electricity	7. electricity	8. two
9. conductors	10. insulators	11. conductor	12. careful

## II. Fill in the blanks

1. Central cap of the cell acts as \_\_\_\_\_ terminal.
2. Container of the cell acts as \_\_\_\_\_ terminal.
3. The device used to break an electric circuit is called \_\_\_\_\_.

1. positive

2. negative

3. switch

## Quiz Time

1. How many terminals a bulb has?
  2. What is filament of a bulb?
  3. When an electric bulb is said to be fused?
  4. What is an electric circuit?
  5. What is switch?
  6. What are conductors?
  7. Is our body conductor or non-conductor of electric current?
  8. Is air an insulator or a conductor?
  9. What +ve and -ve symbols indicate?
  10. What is the difference between dry cell and solar cell?
1. Two terminals.
  2. The thin wire that gives of light is called the filament of the bulb.
  3. When a break in the filament occurs so that there is break in the path of the current.
  4. A complete path for electricity to pass (current to flow) between the two terminals of the electric cell is called electric circuit.
  5. Switch is a simple device that is used to either break the electric circuit or to complete it.
  6. Materials that allow electric current to pass through them are called conductors.
  7. Our body is conductor of electric current.
  8. Air is an insulator.
  9. +ve indicates positive terminal and -ve indicates negative terminal.
  10. Dry cell converts chemical energy into electrical energy whereas solar cell converts solar energy into electrical energy.

1. Intext Questions

1. When you switch on the torch, which part of the bulb glows?

The filament of the bulb glows, when we switch on the torch.

2. Why do the electric cell and the bulb both have two terminals?

It is so because there should be a path for the flow of electricity in a complete circuit.

3. What materials can be used in electric circuit, so that the current can pass through them?

Metals such as aluminium, copper etc. (which are good conductors of electricity).

4. Paheli has another arrangement of the cell and the bulb. Will the torch bulb glow in the following arrangement?

Yes, the torch bulb will glow in this arrangement because the bulb is connected with the cell directly at one terminal and other terminal is connected with the negative of the cell with a wire.

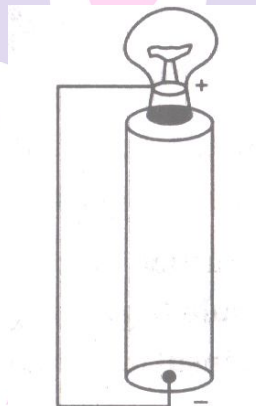

5. Boojho has drawn the inside of the torch as shown in figure. When we close the switch, the circuit is completed and the bulb glows. Can you draw a line on the figure indicating the complete circuit ?

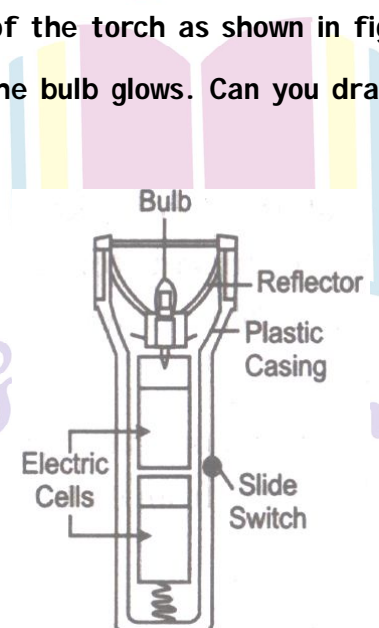

Next 9 School



Yes, we can draw a line on the figure indicating the complete circuits as follows.

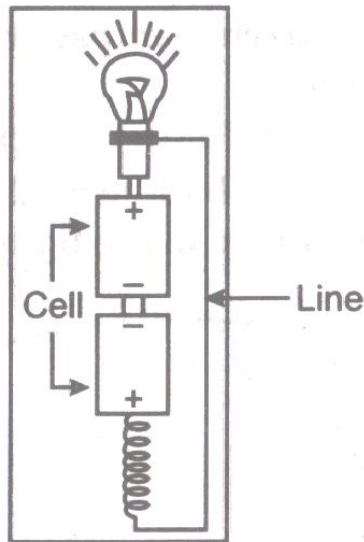

6. Complete the following table. Will bulb glow or not ?

Object used in place of the switch	Material it is made of	Bulb glows ? (Yes/No)
1. Key	Metal	
2. Eraser	Rubber	
3. Scale	Plastic	
4. Matchstick	Wood	
5. Glass bangle	Glass	
6. Iron nail	Metal	
7. Note book	Paper	

Object used in place of the switch	Material it is made of	Bulb glows ? (Yes/No)
1. Key	Metal	Yes
2. Eraser	Rubber	No
3. Scale	Plastic	No
4. Matchstick	Wood	No
5. Glass bangle	Glass	No
6. Iron nail	Metal	Yes
7. Note book	Paper	No

## II. Textbook Questions

### 1. Fill in the blanks :

(a) A device that is used to break an electric circuit is called \_\_\_\_\_.

(a) Switch
------------

### 2. Mark 'True' or 'False' for following statements :

(a) Electric current can flow through metals.

(b) Instead of metal wires, a jute string can be used to make a circuit.

(c) Electric current can pass through a sheet of thermocol .

(a) True

(b) False

(c) False

### 3. Explain why the bulb would not glow in the arrangement shown in the figure :

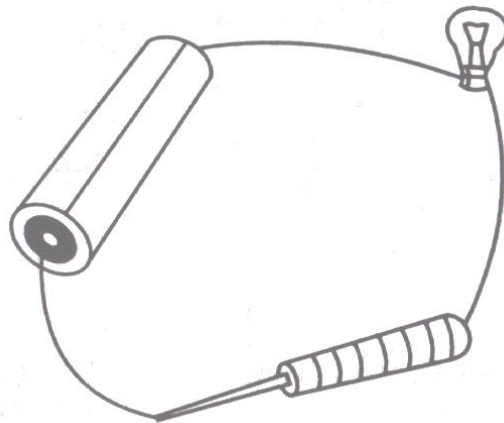

The bulb will not glow because the circuit is disconnected due to presence of an insulator in between.

### 4. Complete the drawing shown in the Fig. to indicate where the free ends of the two wires should be joined to make the bulb glow.

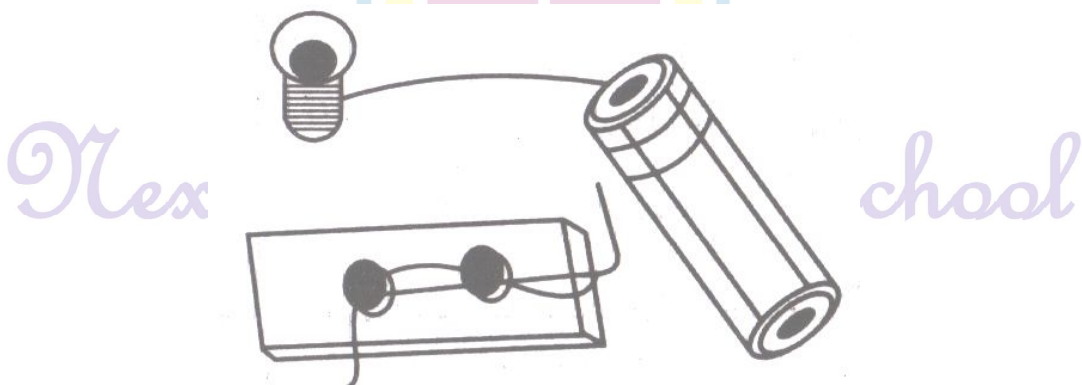

We must join one end of the wire with the free end of cell and the other end with the bulb to complete the circuit. The bulb will glow.

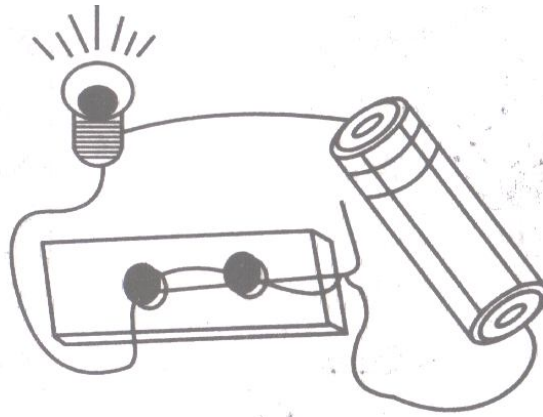

**5. What is the purpose of using electric switch ? Name some electrical gadgets that have switches built into them.**

Switch is a simple device that is used to either break or complete the electric circuit. Electric gadgets that have switches built into them are microwave, oven, fridge, rice cooker, automatic electric iron, toasters etc.

**6. Would the bulb glow after completing the circuit shown in Q. 4., if instead of safety pin, we use an eraser ?**

No, because eraser is made up of rubber which is a bad conductor of electricity.

**7. Would the bulb glow in the circuit shown in Fig. ?**

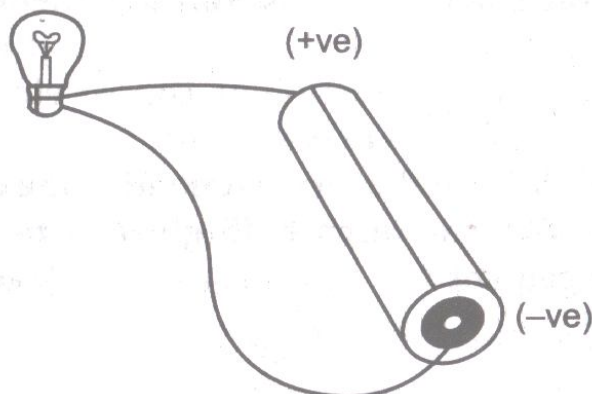

Yes, bulb will glow because current will flow from positive to negative terminals of the cell.

**8. Using the conduction tester on an object, it is found that the bulb begins to glow. Is that object a conductor or an insulator ? Explain.**

The object is a conductor because electricity can pass through only a conductor and not through an insulator.

**9. Why should an electrician use rubber gloves, while repairing an electric switch at your home ? Explain.**

The rubber gloves are insulators. So an electrician should use them to save himself from electric shock, while repairing an electric switch.

**10. The handles of the tools like screwdrivers and pliers used by electricians for repair work usually have plastic or rubber covers on them. Can you explain, why ?**

Plastic and rubber both are insulators. So, they protect the electrician from electric shocks.

---

### I. Very Short Answer Type Questions.

**1. In which of the following circuits A, B and C given in Fig. the cell will be used up very rapidly? [NCERT Exemplar]**

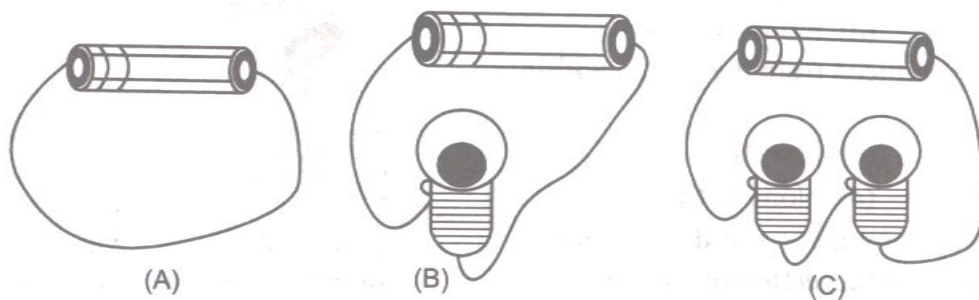

In circuit A, the cell will be used up very rapidly

Because all the current will discharge through the wire very rapidly as no appliance is connected between the + ve and - ve terminals.

**2. What is electricity ?**

It is a form of energy that causes the bulb to glow.

**3. Name two electrical devices.**

Fan, bulb.

**4. How does an electric bulb glow ?**

When current passes through filament, it gets red hot and emits light.

**5. What is the direction of current in an electric circuit ?**

Positive terminal to negative terminal.

**6. How do we arrange cells in an electrical device ?**

We generally arrange cells in series.

**7. Why do we remove plastic coatings from connecting wire before making circuits ?**

To take out wire ends, plastic ends need to be removed.

**8. What is an electric cell ?**

It is a source of electricity.

**9. What are conductors ?**

Materials through which electric current can flow are called conductors.

**10. How does an electric cell produce electricity ?**

The electric cell produces electricity due to chemical reactions that occur inside it.

**11. Why do we get an electric shock ?**

We get an electric shock because our body is a conductor of electricity.

**12. What is a fused bulb ?**

When the filament of a bulb is broken, it is called a fused bulb.

**13. Fig. shows a bulb with its different parts marked as 1, 2, 3, 4 and 5. Which of them label the terminals of the bulb ? [NCERT Exemplar]**

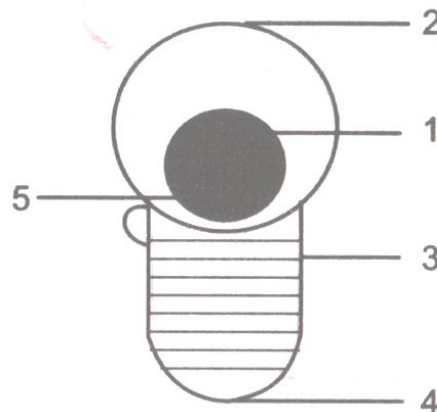

Label 3 and 4 show the terminals of the bulb.

**II. Very Short Answer Type Questions.**

**1. What is the direction of flow of current in a dry cell?**

The current flows in closed circuit from +ve to -ve terminal of cell.

**2. Name the +ve terminal of dry cell.**

Carbon rod with a metal cap on it.

**3. Name the -ve terminal of a dry cell.**

Zinc metal plate.

**4. What is dry cell?**

It is a device which converts chemical energy into electrical energy.

**5. What is solar cell?**

A device which converts solar energy into electrical energy.

**6. What is open circuit?**

An electric circuit in which electrical contact at any point is broken is called open.

**7. Write one use of insulators.**

Insulators are used in making switchboard, handle of testers, screwdrivers.

**8. What is the name of thin wire in the electric bulb?**

Filament.

**9. Name the two terminals of an electric cell.**

i. Positive terminal                      ii. Negative terminal

**10. State the role of electric switch in the circuit.**

It is used either to break the circuit or complete the circuit.

**11. Complete the statement. A break in the filament of an electric bulb means\_\_\_\_\_.**

A break in the path of the current between the terminals of the electric cell.

**12. What is filament of the bulb?**

The thin wire that gives off light is called filament of the bulb.

**13. What is a closed circuit?**

A circuit where there is no gap between two terminals is called a closed circuit.

**14. Do all materials allow electricity to pass through them?**

No.

---

**I. Short Answer Type Questions.**

**1. What are insulators ? Give one example.**

Materials through which electric current cannot flow are called as insulators. For example : rubber.

**3. Name some of the devices in which electric cells are used.**

Some devices which make use of the electric cells are :

- (i) Transistor radio,
- (ii) Camera,
- (iii) Wrist watch,
- (iv) Alarm clock.

**4. Name two insulators and two conductors.**

The two insulators are :

- (i) Plastic (ii) Rubber

The two conductors are :

- (i) Aluminium (ii) Copper

**5. Why should an electrician use rubber gloves while repairing an electric switch ?**

An electrician should use rubber gloves while carrying out electrical repairs, because our body is a good conductor of electricity. When he uses rubber gloves, electricity does not flow in his body, as rubber gloves are insulators.

**6. Explain why all the light bulbs and fans go off if the main switch is turned off in your house.**

Current flows in our house appliances through the main switch. When it is turned off, flow of current stops and our lights and fans go off.

**7. What is a battery ? Explain it with a figure.**

When two or more than two electric cells are connected together in such a way that the positive terminal of one cell is connected to the negative terminal of the other, then we call it a battery. A simple connection showing the combination of two electric cells to form a battery is shown below :

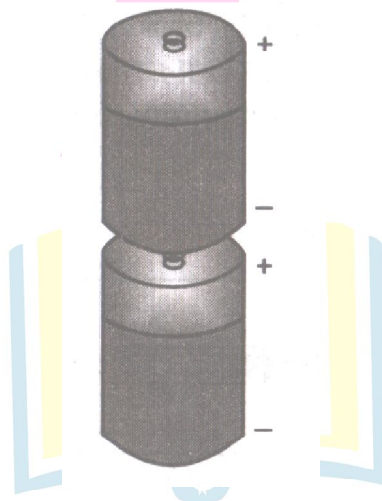

**8. What type of cells are used in calculators ? What are the main advantages of using such type of cells ?**

The cells used in calculators are known as button cells, as they resemble the shape of a button. The plates of these cells are made from compounds of nickel and cadmium. The main advantage of these cell is that they can stay in an active stage for months without any leakage.

**9. How does an electric cell produce electricity?**

The chemical energy stored in the chemicals stored inside a cell converts into electrical energy. When the chemicals of the cell are used up, it stop producing electricity.

**10. You are provided with a bulb, a cell, a switch and some connecting wires. Draw a diagram to show the connections between them to make the bulb glow.**

[NCERT Exemplar]

A diagram to show the connections between them to make the bulb glow is shown below :

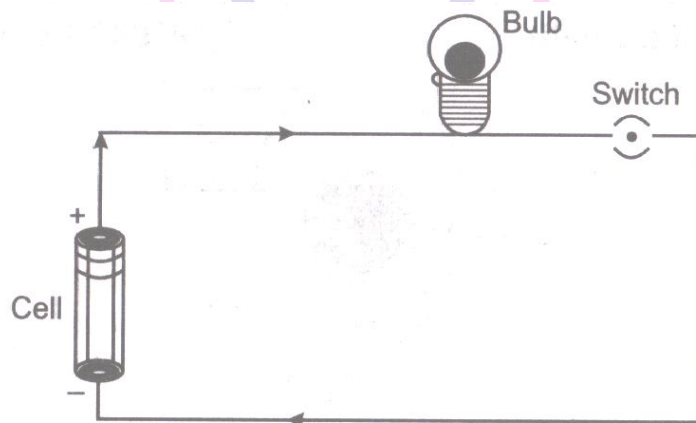

**11. An electric bulb is connected to a cell through a switch as shown in Fig. When the switch is brought in 'ON' position the bulb does not glow. What could be the possible reasons for it ? Mention any two of them.**

[NCERT Exemplar]

The possible reasons could be :

- (i) The pin terminals may be of plastic.
- (ii) The wire may be broken inside.

**12. A torch requires 3 cells. Show the arrangement of the cells, with a diagram, inside the torch so that bulb glows. [NCERT Exemplar]**

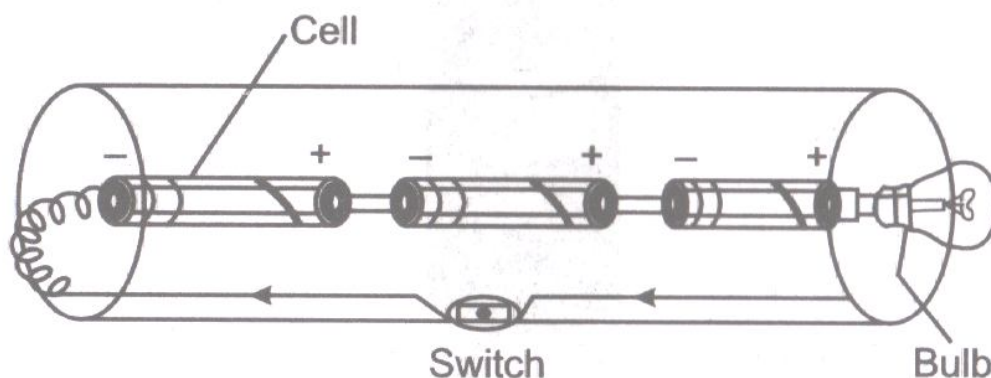



13. When the chemicals in the electric cell are used up, the electric cell stops producing electricity. The electric cell is then replaced with a new one. In case of rechargeable batteries (such as the type used in mobile phones, camera and inverters), they are used again and again. How ? [NCERT Exemplar]

The chemicals present in rechargeable batteries can be restored by passing suitable current in the opposite direction to these batteries, so they are used again and again.

14. Paheli connected two bulbs to a cell as shown in Fig.

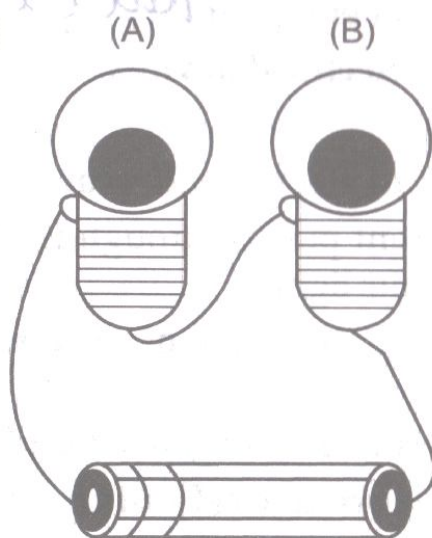

She found that filament of bulb B is broken. Will the bulb A glow in this circuit ? Give reason. [NCERT Exemplar]

No, the bulb 'A' will not glow in this circuit because filament of bulb 'B' is broken which prevents the flow of current in the whole circuit.

15. Why do bulbs have two terminals ? [NCERT Exemplar]

Bulbs have two terminals for the connection of filament with the circuit so that the current can pass through it.

16. Which of the following arrangements A, B, C and D given in Fig. should not be set up?

Explain why ?

[NCERT Exemplar]

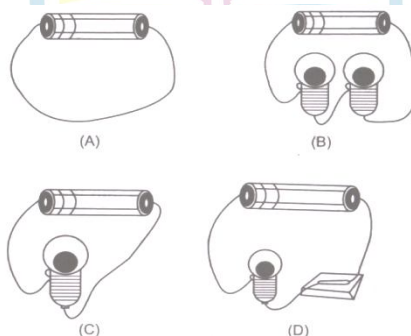

In arrangement 'A', no appliance is connected between positive and negative terminals. So, this arrangement 'A' should not be set up. This will exhaust the cell very rapidly.

**17. A fused bulb does not glow. Why ?**

**[NCERT Exemplar]**

A fused bulb does not glow because the filament is broken in this bulb and the circuit is incomplete. The current will not flow.

**18. Paheli wanted to glow a torch bulb using a cell. She could not get connecting wires.**

**Instead, she got two strips of aluminium foil. Will she succeed? Explain how ?**

**[NCERT Exemplar]**

Yes, she will succeed, because, aluminium is a good conductor of electricity.

## II. Short Answer Type Questions.

**1. Mention two advantages of a dry cell.**

1. It converts chemical energy into electrical energy.
2. It is light and small in size.

**2. Draw a diagram showing the two terminals of a bulb.**

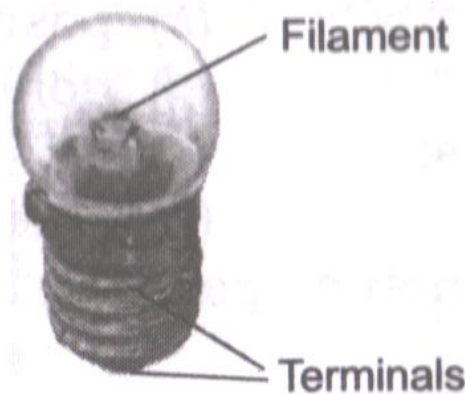

**5. Identify conductors and insulators from the following.**

Eraser, Paper, Matchstick, Copper wire, Pencil lead, Polythene

Conductors : Copper wire, Pencil lead.

Insulator : Eraser, Paper, Matchstick, Polythene.

**6. Name the scientist who invented electric cell and the scientist who invented electric bulb.**

Electric cell : Alessandro Volta.

Electric bulb : Thomas Alva Edison

**7. Give one activity to prove that air is an insulator.**

Take an electric circuit, keep the terminals unconnected in the air. The bulb do not glow, as air is an insulator and does not allow the current to flow through it.

**8. In any electric circuit, when the switch is on and the current flows through it why do the wire, switches, bulb or devices become hot?**

This is because electric energy changes into heat energy.

**9. The headlights of a car have reflectors behind the bulb. What is the function of reflectors?**

The reflector helps in reflecting the light into a focussed area.

**10. If you touch an electric wire carrying current you get a shock, but if on the same wire the birds sit they do not get any shock/current. Explain why?**

When we hold the wire carrying current then the circuit is closed and the current flows from our body and enters earth but the birds sitting on the same wire do not get any current as the circuit is not complete. If the bird touches the earth wire, it will also die due to electric shock.

**11. List the components of an electric circuit?**

A circuit has mostly the following components:

- i. A cell / battery for source of electricity
- ii. Bulb
- iii. Connecting wire
- iv. Switch / key etc.

**12. Explain : When a conduction tester is used on an object, it is found that the bulb begins to glow. Is this object a conductor or an insulator?**

The object allows current to flow and completes the circuit. That is why the bulb beings to glow. The object is a conductor of electricity.

**13. What will happen if you join the two terminals of a cell without connecting them through a switch / a bulb?**

If you join the two terminals of a cell without connecting them through a switch or a bulb, the chemical with electric cell gets used up very fast and the cell will no longer produce electric current and stop working.

## I. Long Answer Type Questions.

### 1. Describe an electric cell with the help of a labelled diagram.

An electric cell consists of a cylindrical pot which is covered by a thick paper sheet. +ve Terminal

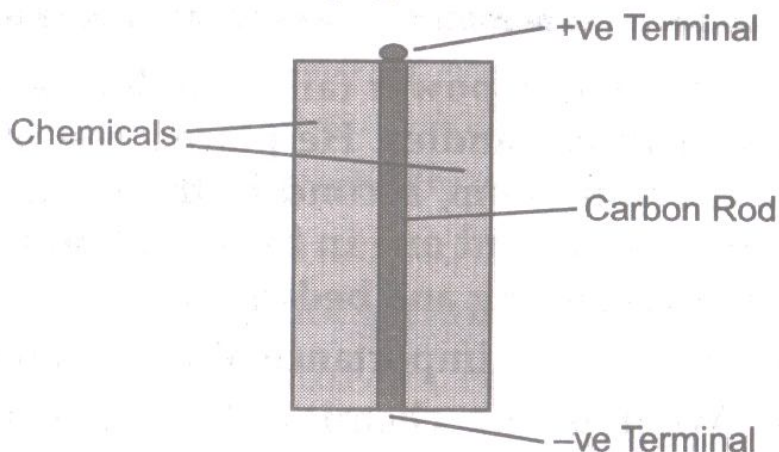

It consists of two terminals. One is called positive terminal and the other is called negative terminal. The metal cap is the positive terminal and the metal disc is the negative terminal of the electric cell. The production of electric current takes place due to the chemical reactions inside the cell. The chemicals are present between the outermost covering of the cell and carbon rod.

### 2. What is an electric switch ? What is the purpose of using it ? Give some examples of electrical appliances where electric switches are used.

An electric switch is a device used to complete or break an electric circuit. Usually, it is manually operated. Purpose of using electric switch : In 'ON' position, the switch allows the current to flow through the circuit. Thus, the circuit becomes a closed circuit. In 'OFF' position, the switch does not allow current to flow through the circuit. Thus , the circuit becomes an open circuit. Examples : Electrical appliances such as fans, electric lamps, washing machines, juicer and mixer, TV radio, etc, have switches.

### 3. Boojho has a cell and a single piece of connecting wire. Without cutting the wire in two, will he be able to make the bulb glow ? Explain with the help of a circuit diagram.

[NCERT Exemplar]

Yes, he will be able to make the bulb glow. It can be understood with the help of following circuit diagram :

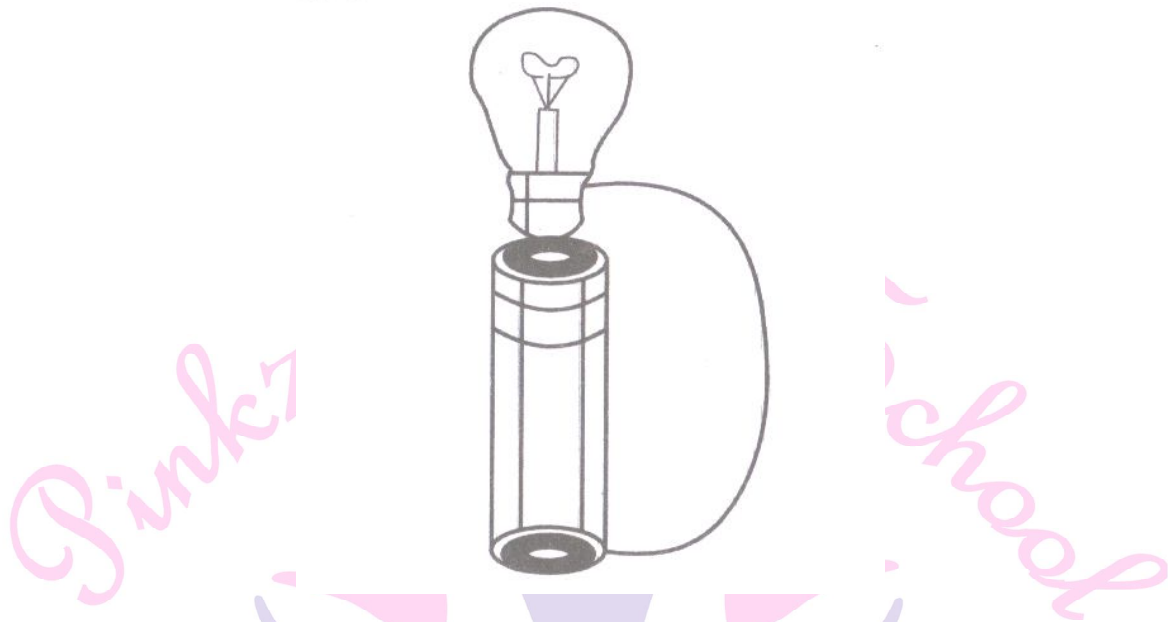

4. Fig. A and B, show a bulb connected to a cell in two different ways.

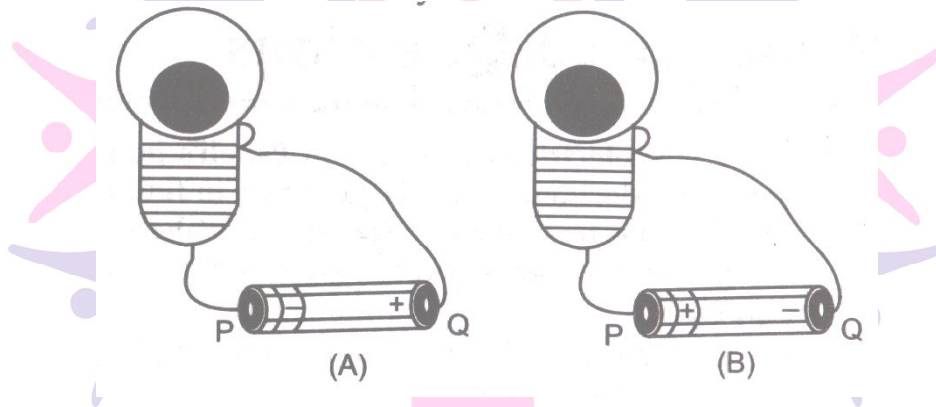

(i) What will be the direction of the current through the bulb in both the cases. (Q to P or P to Q)

(ii) Will the bulb glow in both the cases ?

(iii) Does the brightness of the glowing bulb depend on the direction of current through it ? [NCERT Exemplar]

(i) Current will flow from Q to P in figure A and current will flow from P to Q in figure B. This is because the direction of current is always from +ve terminal to –ve terminal circuit.

(ii) Yes, the bulb will glow in both the cases. Because the circuit is complete in both cases.

(iii) No, the brightness of the glowing bulb does not depend on the direction of current through it.

5. Think of six activities which use electric current. Also name the devices used to perform the activity.

Activity you

	Perform	Device
Example :	Get light	Torch
	_____	_____
	_____	_____
	_____	_____
	_____	_____
	_____	_____

[NCERT Exemplar]

Activity you perform

- (1) Get light
- (2) Get the hot water
- (3) Get the cold water
- (4) Get the moving air
- (5) Do the mechanical work
- (6) Watch movies

Device

- Torch
- Geysers
- Refrigerator
- Fan
- Motor
- Television

6. A torch is not functioning, though contact points in the torch are in working condition.

What can be the possible reasons for this ? Mention any three. [NCERT Exemplar]

The possible reasons for this can be :

- (i) The torch bulb may be fused.
- (ii) The cells are not placed in the correct order.
- (iii) The connecting wires may be broken up.

## II. Long Answer Type Questions.

1. i. What is electric circuit?

ii. How many types of electric circuit are there? Define them.

iii. Draw a diagram to show the closed circuit for switch, bulb and dry cell.

i. An electric circuit is a path in which electrons from a voltage or current source flow.

Electric current flow in a closed path called an electric circuit.

ii. There are two types of electric circuit.

a. Open electric circuit

b. Closed electric circuit

a. **Open electric circuit:** The circuit in which electrical contact at any point is broken is called open electric circuit.

b. **Closed electric circuit:** The circuit in which electric current flows from one terminal of a cell or battery to the other is called a closed circuit.

iii.

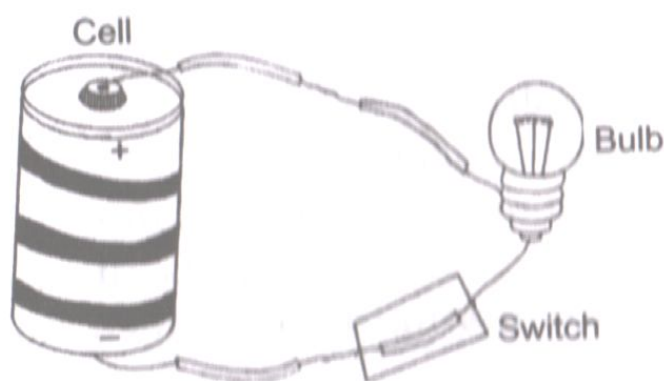

2. Complete the following table (conductors and insulators)

S.No	Object used in place of the switch	Material it is made of	Bulb glows? (Yes / No)
1	Key	Metal	Yes
2	Erase	Rubber	No
3	Scale	Plastic	No
4	Matchstick	Wood	No
5	Glass Bangle	Glass	No
6	Iron nail	Metal	Yes

Next Generation School

## High Order Thinking Skill (HOTS) Questions

1. How can you explain that the human body is a good conductor of electricity?

Human body is a good conductor of electricity because if we stand barefoot on the ground and touch an electric wire, we will get an electric shock.

2. Why is it compulsory to keep a fire extinguisher near the meter room of housing societies?

It is compulsory to keep a fire extinguisher near the meter room of housing societies so that it can be used easily to house electric fires caused by electric sparks.

## Skill based Questions

1. Identify the (+) positive and (-) negative terminal of a cell.

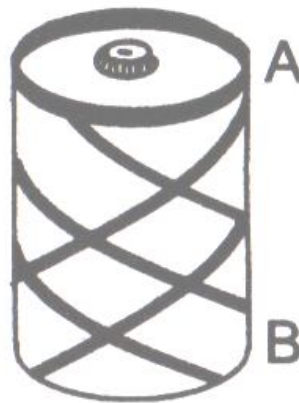

A is (+) positive and B (-) negative.

2. i. What does the following sign represent?  
ii. Name one place where it is used or displayed?



i. Danger sign

ii. Electric substations/Poles.



3. Label the parts marked I to V.

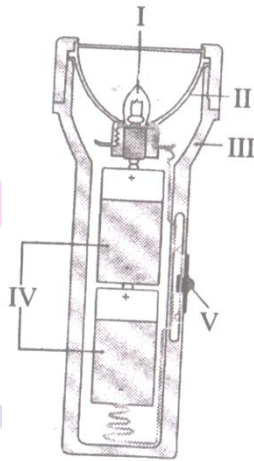

I - Bulb

II - Reflector

III - Plastic casing

IV - Electric cell

V - Slide switch

### Crossword Puzzle

1. Solve the crossword puzzle with the clues given below.

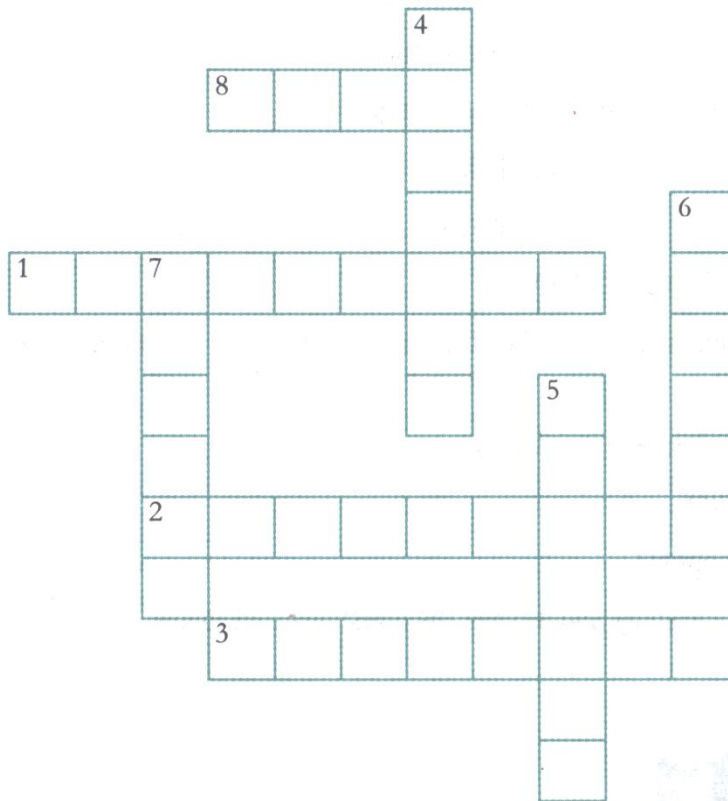

#### Across

1. A material through which current cannot flow
2. A material through which current can flow

3. Part of an electric bulb that glows when electric current flows through it.
8. A device which produces electricity.

**Down**

4. An example of an insulator.
5. Two or more cells joined together.
6. An example of a conductor
7. A device that opens or closes a circuit.

**Across**

1. insulator
2. conductor
3. filament
8. cell

**Down**

4. plastic
5. battery
6. copper
7. switch

*Pinkz Public School*

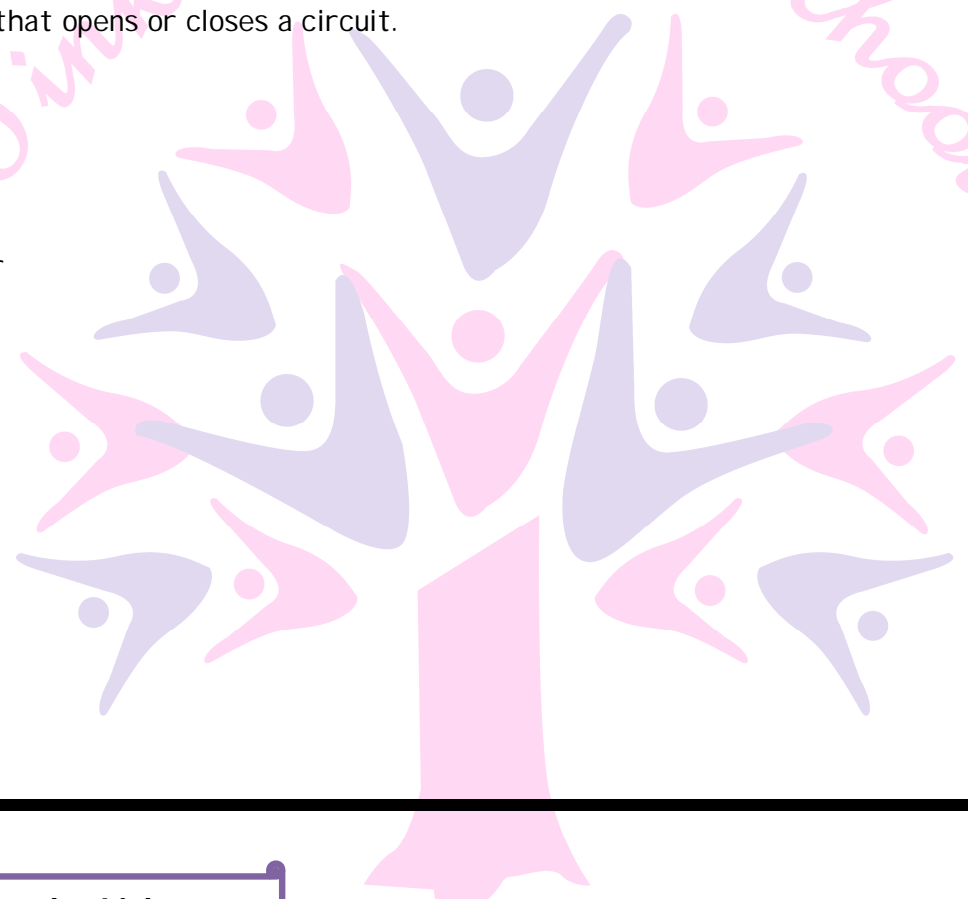

**Know the Links**

- [www.byjus.com](http://www.byjus.com)
- [www.learnbse.in](http://www.learnbse.in)
- [www.exellup.com](http://www.exellup.com)
- [www.studyrankers.com](http://www.studyrankers.com)



*Next Generation School*

